

32" 42" 47"  
**TOUCH SCREEN**  
LCD



*a Perfect Integration!*

- Multi**T**ouch
- Projected capacitive

## Touch Screen

Technology:

- Projected capacitive technology (anti-vandal)
- Optical infrared technology

Infrared technology manages 2 or more touches contemporaneously.

The infrared model recognise the presence of any body (fingers, gloves, plastic pens, ...)

Controller : USB



## LCD

- Professional HD ready
- Rear removable tray
- Inputs : RGB, VGA, CVBS, Svideo, [DVI-D]
- Audio : 2 x 10w



## Integrated PC

- Processor : Intel 1.6GHz fanless
- RAM : 1Gb
- Storage : SSD 16Gb (diskless) or HD 160Gb
- LAN : onBoard 10/100
- Inputs : USB, mouse, keyboard, RS232



(The suggested configuration can be changed according to customer's requests)

# Brackets

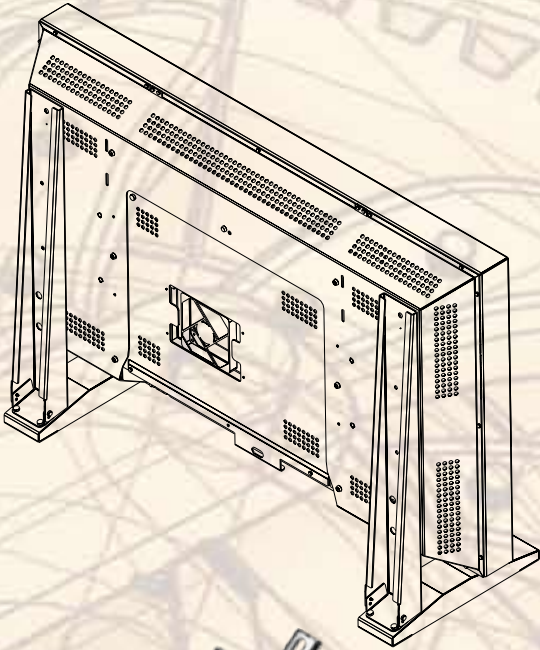

## Desk Stand

The pedestal allows you to place monitor on every flat surface.

Moreover it allows to absorb the pressure exercised on the touch screen so to give stability to the monitor.

Removable rear tray is not obstructed by the pedestal.



## VESA Wall

Bracket for the wall fixing.

It is possible an inclination of 10° downwards.

## Telescopic Arm

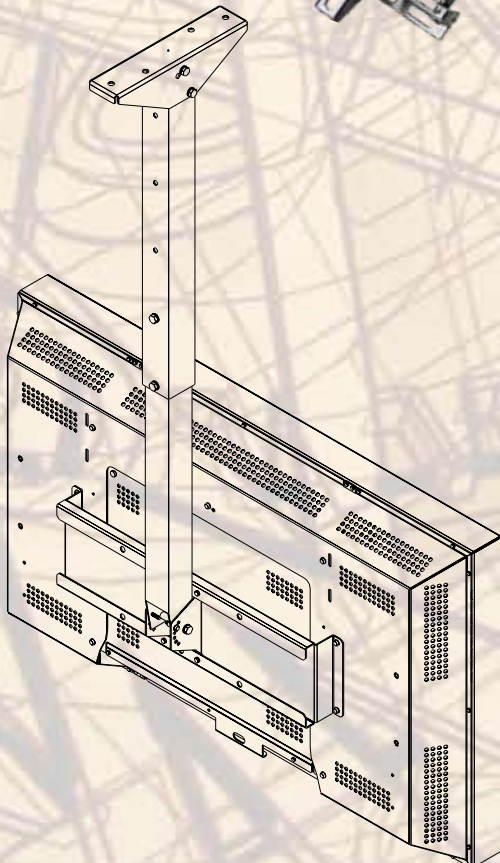

Arm for the ceiling fixing.

It allows monitor inclination from 0° to 90° vertically.

Furthermore there is an additional adjustment that allows you to outdistance monitor from the fixing point.

The telescopic arm is available in 60-90 cm and 110-190 cm versions.

# Touch Screen

## Multitouch Infrared version

Power supply	USB 65mA-110mA 90mA*
Touch method	Finger, Glove, and Stylus or any pointing device with 3mm diameter or above
Touch durability	Unlimited
Touch Accuracy	0.3mm to 2.5mm, 0.5mm typical*
Resolution	12 Million Points over the touch area
Frame Rate	70-100fps
Reporting Rate	5-10 ms
ESD	Contact Discharge 8kV, air discharge 15kV
Temperature	Operating: -5°C to 65°C Storage: -25°C to 90°C
Humidity	10% to 90% RH, non-condensing
Transparency	>92% including glass overlay
Sealability	NEMA 4 and IP65 Standards ready
Communication	USB-HID Digitizer or USB-HID Mouse
Operating System	all Windows, Linux** (most distribution) and MAC (Factory calibration in Windows)

Two simultaneous Touches Windows 7 Certified  
Supports Extended Desktop of up to 64 screens

\*Dependant on Panel Size

\*\*Tested on most Linux distributions

## AntiVandal Projected Capacitive version

Technology	Projected Capacitive
Connectivity	USB v1.1, USB 2.0 compatible
Power	<100mA from 5V USB
Positional Accuracy	<1.5% of reported position in recommended viewing area
Response Time	Direct Touch ~20mS to ~40mS, Through Touch ~60mS
Calibration Drift	Fixed embedded technology, non-contact with active sensor, zero moving parts
Abrasion Resistance	Glass, unaffected by surface scratching
Chemical Resistance	Glass, unaffected by cleaning solutions
Stylus Type	Finger, glove operable
Glass Type	Soda Lime
Sensor Thickness	~7.8mm Direct Touch option ~5.8mm Through Touch option
Light Transmission	~88%.
Surface Finishes	Plain or anti-glare etch Other finishes available upon request
EMC	CE, FCC-B (when fully integrated into final product)
Safety	Laminated glass assembly complies with EN60950, UL60950, UL544
NEMA	Sealable to NEMA 12-4
Operating	-35°C to +65°C
Storage	-40°C to +70°C
Humidity	0 to 90% RH @ 40°C, unaffected by condensation.

# Professional LCD

## Connections

### STANDARD version

Video	CVBS (RCA) SVIDEO Y/C (mini DIN) SVIDEO Differential (RJ45)
Analog RGB	PC (Dsub-15 HD) PC Differential (RJ45) Game (Dsub-9)
Audio	Video (RCA) RGB (RCA)
Control	RS232 (Dsub-9 female)
Power	VDE
Touch screen	USB

### PERSONAL COMPUTER version

According to the personal computer configuration

#### Typical configuration

Processor	1.6GHz Fanless
Storage	HD 160Gb or SSD 16Gb
RAM	1Gb
LAN	2 x 10/100/1000
Interfaces	RS232, USB, mouse, keyboard
Video	Internal
Audio	Internal
Touch screen	Internal

## Physical

Mains voltage	115/230VAC ±15%
Frequency	50/60Hz
Storage	-20°C ~ +65°C
Operating	0°C ~ +45°C
RH	85% not condensing
Class protection	IP30

## Accessories

Power cable  
Video cable  
User manual  
Drivers

## Features

Video compatibility	PAL (BGH/D/I, M, N, 60), NTSC (M, 4.43), SECAM
Video signal level	CVBS 1 Vpp / 75 Ohm - nominal (with AGC)
PC compatibility	Automatic frequency detection
PC signal level	RGB: 0.7 Vpp / 75 Ohm (RGB), TTL (HV)
Frequency range	Horizontal: 20 KHz - 82 KHz Vertical: 55 Hz - 90 Hz
Control interface	RS-232 Serial Port. OnBoard Keypad Commands and controls are available from any of user's interfaces

## Controls

Video	Brightness, Contrast, Color Sharpness, Color temperature Still frame Source selection
Geometry	Self adj of picture dimension Free adj of picture position Selection of format preset (for compatibility with 4:3 and 16:9 pictures) Uncompressed mode
Audio	Volume, Balance Equalizer MTS
Others	Programmable OSD aspect Timer Display address selection DPMS Auto input search
Language	English

## LCD 32"



### Display Panel

Screen size	32" (81 cm)
Aspect Ratio	16:9
Resolution	1366x768 pixel
Pixel pitch	0,51x0,51 mm
Brightness	500cd/m <sup>2</sup>
Contrast	4000:1 (dyn)
Viewing angle	178°
Colours	16.8 Mil
Response time	8 msec

### Features

PC compatibility	VGA ~ WXGA (1280x1024), NATIVE (1366x768)
------------------	--

### Physical

Dimensions	778 (W) x 468 (H) x 114 (D)
Weight	24Kg + touch screen
Power	112w

## LCD 42"



### Display Panel

Screen size	42" (107 cm)
Aspect Ratio	16:9
Resolution	1366x768 pixel
Pixel pitch	0,68x0,68 mm
Brightness	500cd/m <sup>2</sup>
Contrast	4000:1 (dyn)
Viewing angle	178°
Colours	16.8 Mil
Response time	8 msec

### Features

PC compatibility	VGA ~ WXGA (1280x1024), NATIVE (1366x768)
------------------	--

### Physical

Dimensions	1007 (W) x 600 (H) x 121 (D)
Weight	31Kg + touch screen
Power	199w

## LCD 47" Narrow Bezel



Display Panel	blackening defect free
Screen size	47" (119 cm)
Aspect Ratio	16:9
Resolution	1920 x 1080 pixel
Pixel pitch	0,54 x 0,54 mm
Brightness	700cd/m <sup>2</sup>
Hi Brightness	1500cd/m <sup>2</sup> (optional)
Contrast	9000:1 (dyn)
Viewing angle	178°
Colours	16.8 Mil
Response time	8 msec

Features	
PC compatibility	VGA ~ WUXGA (1920x1080), NATIVE (1920x1080)
Physical	
Dimensions	1073 (W) x 618 (H) x 200 (D)
Bezel	16mm
Weight	35Kg + touch screen
Power	260w

[www.hantarex.com](http://www.hantarex.com)

HANTAREX INTERNATIONAL LTD  
Unit 14 - Forest Hill Business Centre  
Clyde Vale  
Forest Hill  
London  
SE23 3JF



Tel: +44(0) 20 8778 1414  
Fax: +44(0) 20 8659 9348  
[www.hantarex.com](http://www.hantarex.com)  
[sales@hantarex.com](mailto:sales@hantarex.com)